

REV	DATE	DESCRIPTION	APP.
NEW	<DATE>	NEW DRAWING	<INIT>

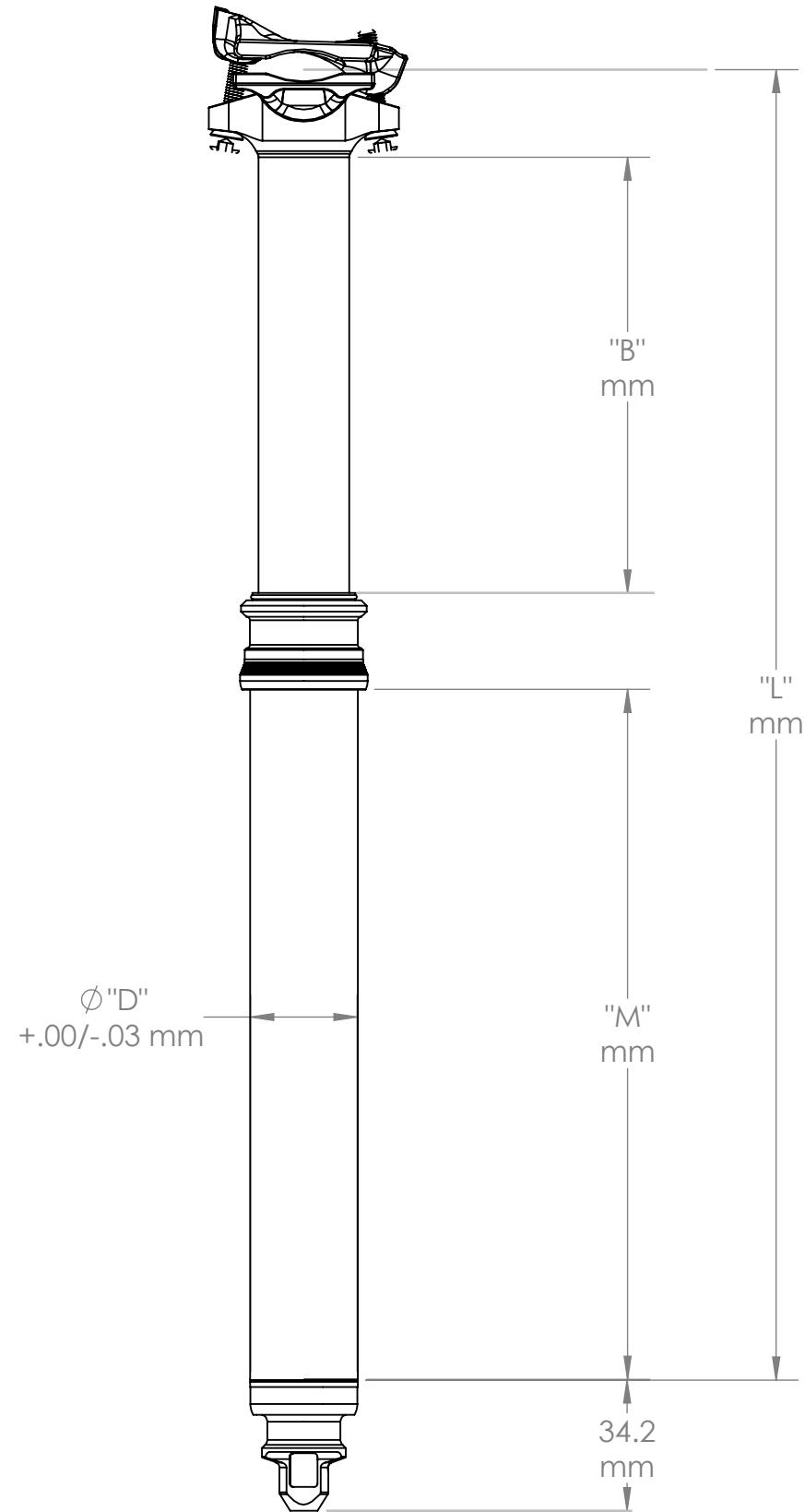

Model Number	Description	"L"	"M"	"B"	"D"
		Overall Length	Max. Insertion Length	Travel	Seatpost Diameter
DP-C104	30.9 X 375 mm	375 mm	210.6 mm	100 mm	30.9 mm
DP-C105	30.9 X 400 mm	400 mm	210.6 mm	125 mm	30.9 mm
DP-C106	30.9 X 450 mm	450 mm	233.6 mm	150 mm	30.9 mm
DP-C107	31.9 X 375 mm	375 mm	210.6 mm	100 mm	31.9 mm
DP-C108	31.9 X 400 mm	400 mm	210.6 mm	125 mm	31.9 mm
DP-C109	31.9 X 450 mm	450 mm	233.6 mm	150 mm	31.9 mm
DP-C111	34.9 X 400 mm	400 mm	210.6 mm	125 mm	34.9 mm
DP-C112	34.9 X 450 mm	450 mm	233.6 mm	150 mm	34.9 mm

UNLESS OTHERWISE SPECIFIED
DIMENSIONS ARE IN INCHES (mm)
TOLERANCES:
ANGLES $\pm 1^\circ$ DECIMALS $\pm .010$ (.25)
FINISH 125 (3.2) RA MAX
BREAK CORNERS .01-.02 RAD

USED ON:	DRAWN:	DATE:	L.H. THOMSON COMPANY CORPORATE OFFICES MACON, GA 31216
CHECKED:	DATE:		
QA:	DATE:		
SECTION NO.			Dropper Post - Internal Cable (100 - 150mm)
CHANGE NO.			SIZE: B CAGE CODE: DRAWING NO. WEB 10
FILE: \\BIKE THOMSON\113\142\WEBSITE DATA\010 NEW DROPPER SEATPOST Rev New			SHEET 3 OF 5