

REV.	DATE	DESCRIPTION	APPR.
A	3/25/08	REMOVED NONEXISTENT PART #s	ERL
B	1/8/13	UPDATED DIAMETERS TO MATCH NOMINAL SIZES	ERL

Model Number	Description	"L"	"M"	"B"	"D"
		Over All Length	Min. Insertion Length	Usable Length	Seatpost Diameter
SP-M102	27.2 X 240 mm	240 mm	63.5 mm	176.5 mm	27.2 mm
SP-M105	27.2 X 330 mm	330 mm	63.5 mm	266.5 mm	27.2 mm
SP-M106	30.9 X 350 mm	350 mm	87.0 mm	263.0 mm	30.9 mm
SP-M107	31.6 X 350 mm	350 mm	87.0 mm	263.0 mm	31.6 mm

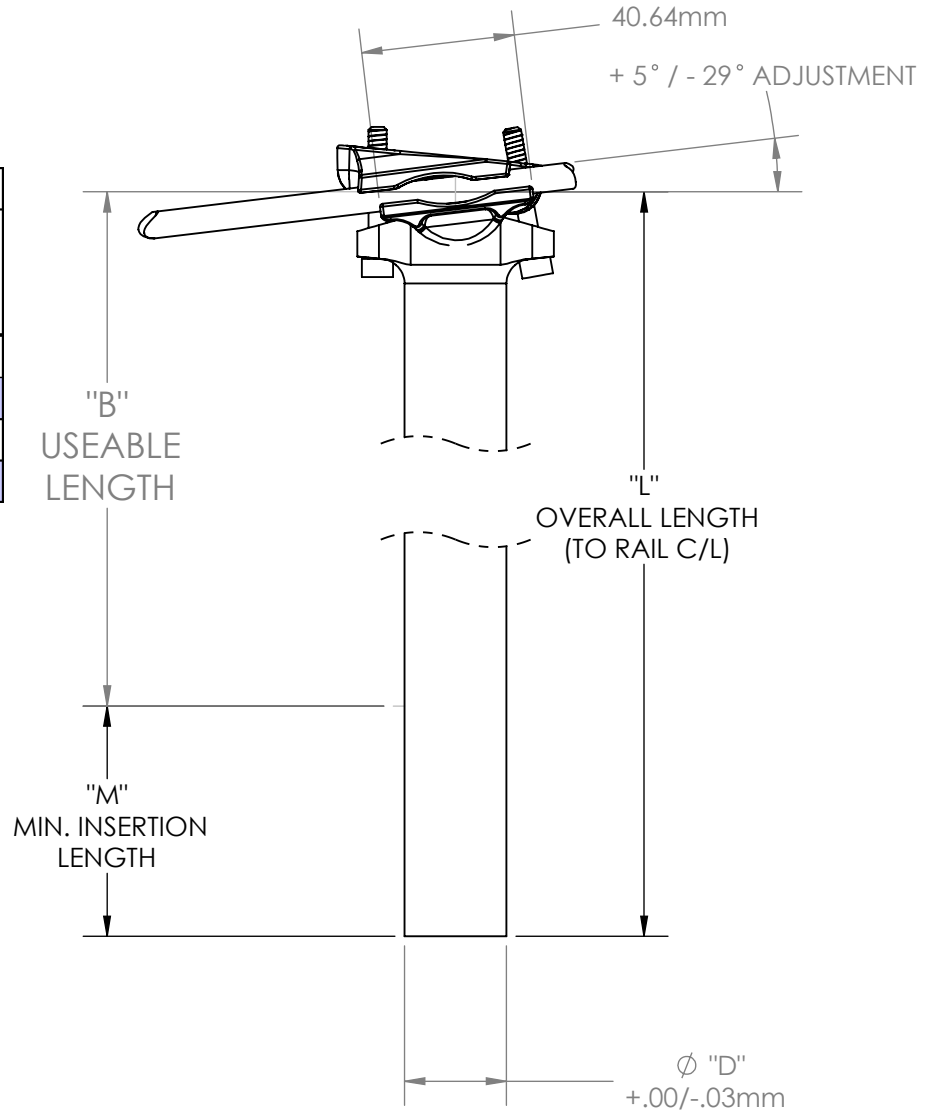

THIS DOCUMENT/DATA RECORD IS THE PROPERTY OF L.H. THOMSON CO. AND CONTAINS PROPRIETARY AND CONFIDENTIAL INFORMATION, AND IS NOT TO BE COPIED UNLESS OTHERWISE SPECIFIED. DIMENSIONS ARE IN INCHES (mm) TOLERANCES: ANGLES $\pm 1^\circ$ DECIMALS $\pm .010$ (.25) FINISH 125 (3.2) RA MAX BREAK CORNERS .01-.02 RAD

USED ON:	DRAWN: R. De Rose	DATE: 12/12/04	L.H. THOMSON COMPANY CORPORATE OFFICES MACON, GA 31297
L.H. Thomson Web Site	CHECKED: D.Parrett	DATE: 2/12/04	
SECTION NO.	STRESS:	DATE:	MASTERPIECE SEATPOST SIZE DIAGRAM
	ENGR:	DATE:	
CHANGE NO.	M.E.:	DATE:	SIZE CAGE CODE DRAWING NO.
	GROUP:	DATE:	
GROUP ORIGIN:	PROJ.	DATE:	WEB 003
			SHEET 1 OF 1