

REV.	DATE	DESCRIPTION	APP.
A	3/25/08	REMOVED NONEXISTENT PART #s	ERL
B	4/7/11	ADDED SP-E159 AND SP-E160	ERL
C	12/11/12	UPDATED DIAMETERS TO MATCH NOMINAL SIZES	ERL
D	10/30/15	UPDATED PARTS TABLE	CJ

Model Number	Description	"L"	"M"	"B"	"D"
		Over All Length	Min. Insertion Length	Usable Length	Seatpost Diameter
SP-E156	25.0 x 330 mm	330 mm	63.5 mm	266.5 mm	25.0 mm
SP-E150	25.4 x 330 mm	330 mm	63.5 mm	266.5 mm	25.4 mm
SP-E161	26.0 x 330 mm	330 mm	63.5 mm	266.5 mm	26.0 mm
SP-E118	26.6 x 330 mm	330 mm	71.1 mm	266.5 mm	26.6 mm
SP-E105	26.8 x 330 mm	330 mm	63.5 mm	266.5 mm	26.8 mm
SP-E103	27.0 x 330 mm	330 mm	63.5 mm	266.5 mm	27.0 mm
SP-E114	27.0 x 410 mm	410 mm	76.2 mm	333.8 mm	27.0 mm
SP-E102	27.2 x 250 mm	250 mm	63.5 mm	186.5 mm	27.2 mm
SP-E101	27.2 x 330 mm	330 mm	63.5 mm	266.5 mm	27.2 mm
SP-E113	27.2 x 410 mm	410 mm	76.2 mm	333.8 mm	27.2 mm
SP-E121	27.4 x 250 mm	250 mm	63.5 mm	186.5 mm	27.4 mm
SP-E120	27.4 x 330 mm	330 mm	63.5 mm	266.5 mm	27.4 mm
SP-E153	27.4 x 410 mm	410 mm	76.2 mm	333.8 mm	27.4 mm
SP-E122	28.6 x 330 mm	330 mm	63.5 mm	266.5 mm	28.6 mm
SP-E140	29.0 x 410 mm	410 mm	76.2 mm	333.8 mm	29.0 mm
SP-E142	29.4 x 330 mm	330 mm	63.5 mm	266.5 mm	29.4 mm
SP-E143	29.4 x 410 mm	410 mm	76.2 mm	333.8 mm	29.4 mm
SP-E145	29.8 x 330 mm	330 mm	63.5 mm	266.5 mm	29.8 mm
SP-E146	29.8 x 410 mm	410 mm	76.2 mm	333.8 mm	29.8 mm
SP-E148	30.0 x 330 mm	330 mm	63.5 mm	266.5 mm	30.0 mm
SP-E149	30.0 x 410 mm	410 mm	76.2 mm	333.8 mm	30.0 mm
SP-E160	30.6 x 367 mm	367 mm	100 mm	267 mm	30.6 mm
SP-E131	30.8 x 367 mm	367 mm	100 mm	267 mm	30.8 mm
SP-E130	30.8 x 410 mm	410 mm	100 mm	310 mm	30.8 mm
SP-E128	30.9 x 367 mm	367 mm	100 mm	267 mm	30.9 mm
SP-E127	30.9 x 410 mm	410 mm	100 mm	310 mm	30.9 mm
SP-E109	31.6 x 367 mm	367 mm	100 mm	267 mm	31.6 mm
SP-E116	31.6 x 410 mm	410 mm	100 mm	310 mm	31.6 mm
SP-E155	32.4 x 367 mm	367 mm	100 mm	267 mm	32.4 mm

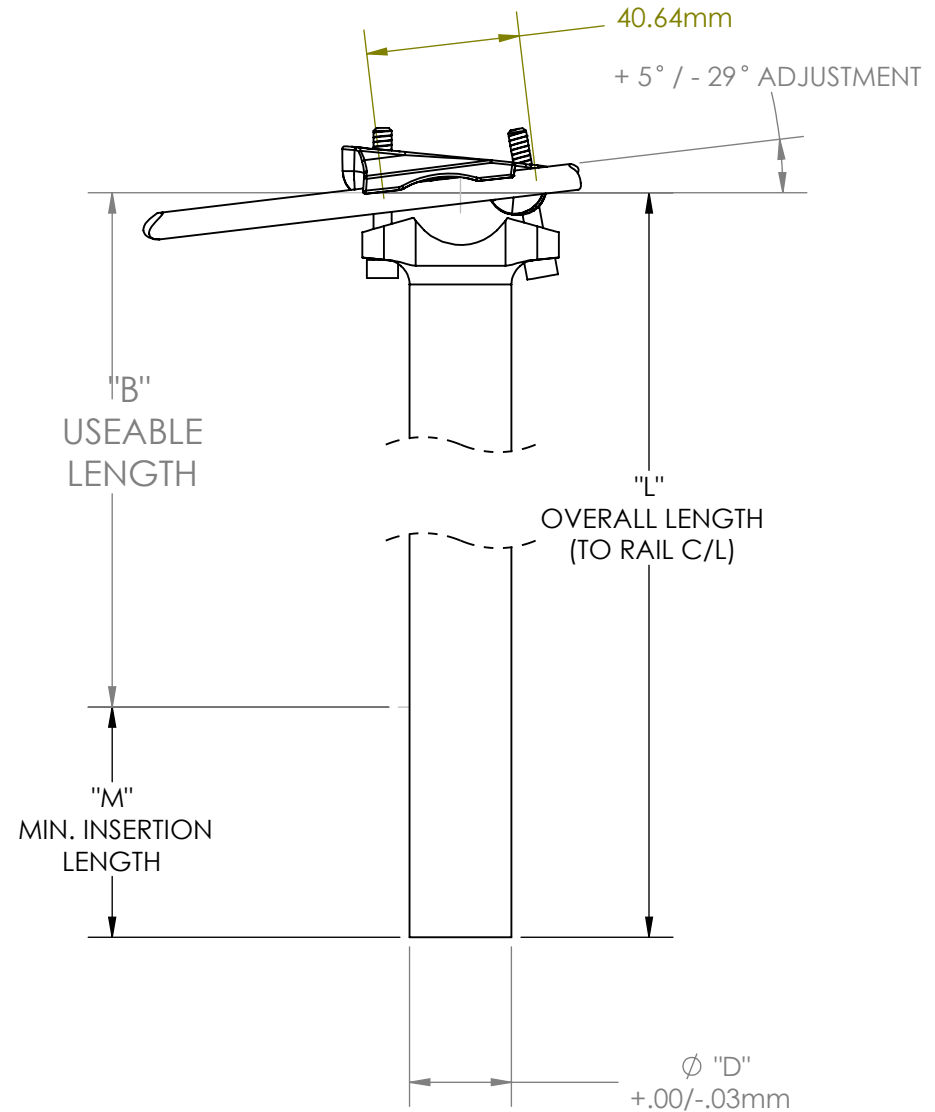

THIS DOCUMENT/DATA RECORD IS THE PROPERTY OF L.H. THOMSON CO. AND CONTAINS PROPRIETARY AND CONFIDENTIAL INFORMATION, AND IS NOT TO BE COPIED, UNLESS OTHERWISE SPECIFIED. DIMENSIONS ARE IN mm. TOLERANCES: ANGLES ± 1° DECIMALS ± .25 FINISH 3.2 RA MAX BREAK CORNERS .30-.60 RAD

USED ON:	DRAWN: R. De Rose	DATE: 12/12/04	L.H. THOMSON COMPANY CORPORATE OFFICES MACON, GA, 31297		
L.H. Thomson Web Site	CHECKED: D.Parrell	DATE: 12/12/04			
SECTION NO.	ENGR:	DATE:	ELITE SEATPOST SIZE DIAGRAM		
CHANGE NO.	M.E.:	DATE:			
GROUP ORIGIN:	GROUP:	DATE:	SIZE	CAGE CODE	DRAWING NO.
	PROJ.	DATE:			WEB 001
					SHEET 1 OF 1