

REV	DATE	DESCRIPTION	APP.

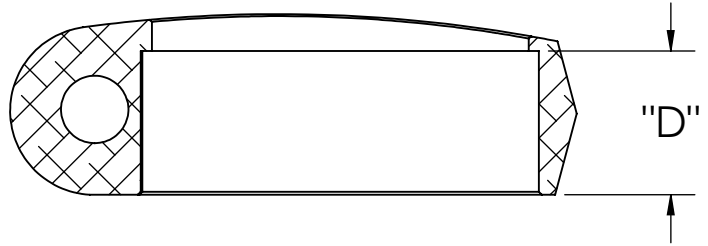
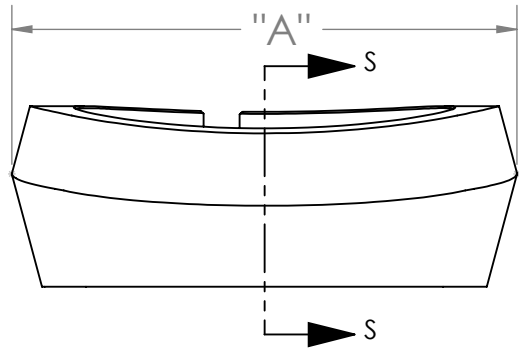
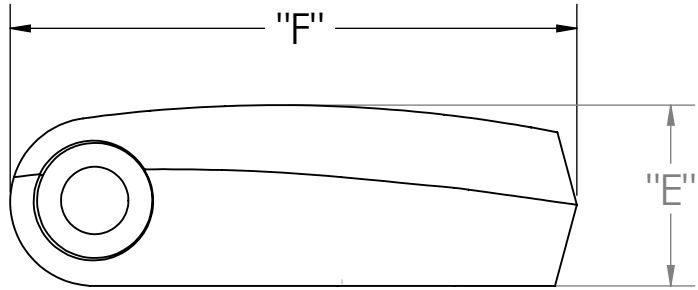
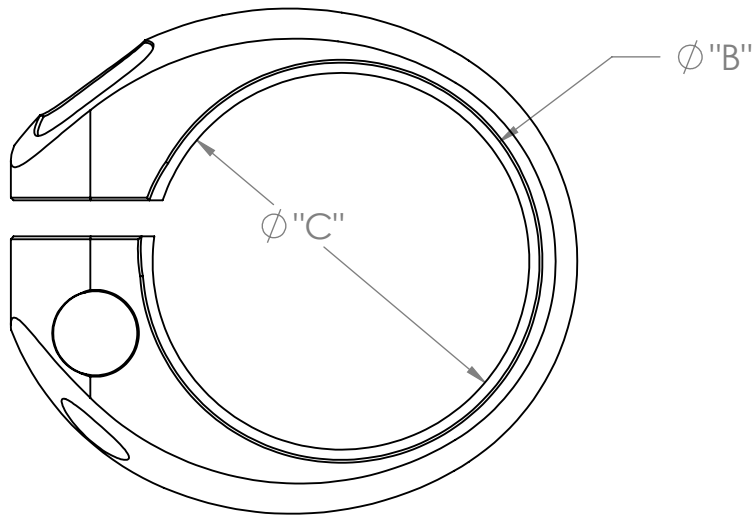

SECTION S-S
SCALE 1.5 : 1

MODEL #	WEIGHT	"A" OVERALL WIDTH	"B" INSIDE DIAMETER	"C" BEAUTY RING DIAMETER	"D" INSERTION HEIGHT	"E" OVERALL HEIGHT	"F" LENGTH
SC-E101	26g	37.7mm	28.6mm	28.0mm	12.7mm	15.7mm	43.9mm
SC-E102	26g	39.5mm	29.8mm	29.1mm	12.7mm	15.7mm	45.2mm
SC-E103	27g	41.4mm	31.8mm	30.8mm	12.7mm	16.0mm	47.0mm
SC-E104	27g	44.6mm	34.9mm	33.7mm	12.7mm	15.9mm	50.0mm
SC-E105	28g	46.1mm	36.4mm	34.7mm	12.7mm	16.0mm	51.5mm

NOTE: MARK ALL GAGES AND FIXTURES WITH GAGE/FIXTURE NUMBER, AND MARK PART NUMBERS IT'S USED FOR IN A DIFFERENT LOCATION.

UNLESS OTHERWISE SPECIFIED
DIMENSIONS ARE IN INCHES (mm)
TOLERANCES:
ANGLES ± 1° DECIMALS ± .010 (.25)
FINISH 125 (3.2) RA MAX
BREAK CORNERS .01-.02 RAD

USED ON: <PROJ. NAME>	DRAWN: E.LASSITER CHECKED: <NAME>	DATE: 7/1/2011 DATE: <DATE>	L.H. THOMSON COMPANY <small>CORPORATE OFFICES</small> <small>MACON, GA. 31297</small>
SECTION NO.	STRESS: ENGR:	DATE: DATE:	
CHANGE NO.	M.E.: GROUP: PROJ.	DATE: DATE: DATE:	
SIZE: A CAGE CODE: DRAWING NO.:			005-SEAT POST COLLAR- DIMENSION SKETCH
FILE: I:\cad\prt\113101\website info\005 Seat Post Collar Dimension Sketch.SLDRW			SHEET 1 OF 1